

Student Name: _____

Date: _____

Contact Person Name: _____

Phone Number: _____

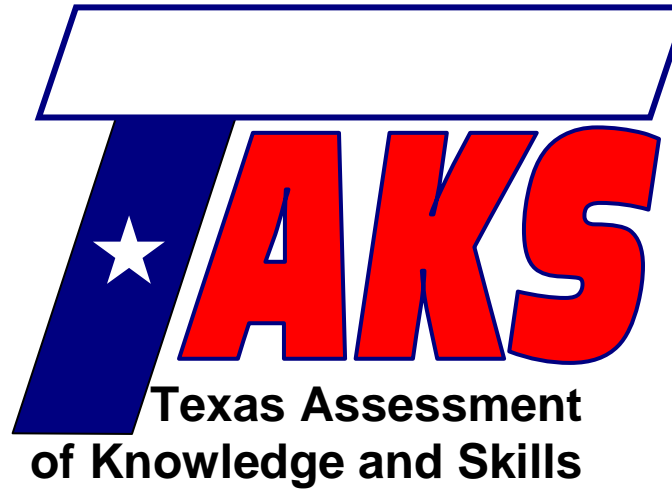

Exit Level Math Review

Lesson 29

Test-Taking Strategies

TAKS Objective 10 – Demonstrate an understanding of the mathematical processes and tools used in problem solving

Lesson Objectives:

- Determine tips for a successful test-taking experience
- Use mental math to improve efficiency of answering questions
- Use reasoning to eliminate choices that do not make sense

Authors:

Tim Wilson, B.A.
Jason March, B.A., M.S.Ed

Editor:

Linda Shanks

Graphics:

Tim Wilson
Jason March

The Texas Assessment of Knowledge and Skills (TAKS) exit level exam covers ten learning objectives. These lessons are designed to teach math concepts specific to each objective as well as strategies to consider when approaching typical TAKS questions. To successfully complete the TAKS exit level exam, the student should be able to:

- 1) Describe functional relationships in a variety of ways;
- 2) Demonstrate an understanding of the properties and attributes of functions;
- 3) Demonstrate an understanding of linear functions;
- 4) Formulate and use linear equations and inequalities;
- 5) Demonstrate an understanding of quadratic equations and other nonlinear functions;
- 6) Demonstrate an understanding of geometric relationships and spatial reasoning;
- 7) Demonstrate an understanding of two- and three-dimensional representations of geometric relationships and shapes;
- 8) Demonstrate an understanding of concepts and uses of measurement and similarity;
- 9) Demonstrate an understanding of percents, proportional relationships, probability, and statistics in application problems;
- 10) Demonstrate an understanding of the mathematical processes and tools used in problem solving.**

National PASS Center
BOCES Geneseo Migrant Center
27 Lackawanna Avenue
Mount Morris, NY 14510
(585) 658-7960
(585) 658-7969 (fax)
www.migrant.net/pass



Developed by the National PASS Center under the leadership of the National PASS Coordinating Committee with funding from the Region 20 Education Service Center, San Antonio, Texas, as part of the Mathematics Achievement = Success (MAS) Migrant Education Program Consortium Incentive project.

National PASS Center, 2010. This book may be reproduced without written permission from the National PASS Center.

TAKS Mathematics Chart



Length

Metric

1 kilometer = 1000 meters
1 meter = 100 centimeters
1 centimeter = 10 millimeters

Customary

1 mile = 1760 yards
1 mile = 5280 feet
1 yard = 3 feet
1 foot = 12 inches

Capacity and Volume

Metric

1 liter = 1000 milliliters

Customary

1 gallon = 4 quarts
1 gallon = 128 fluid ounces
1 quart = 2 pints
1 pint = 2 cups
1 cup = 8 fluid ounces

Mass and Weight

Metric

1 kilogram = 1000 grams
1 gram = 1000 milligrams

Customary

1 ton = 2000 pounds
1 pound = 16 ounces

Time

1 year = 365 days
1 year = 12 months
1 year = 52 weeks
1 week = 7 days
1 day = 24 hours
1 hour = 60 minutes
1 minute = 60 seconds

TAKS Mathematics Chart

Perimeter	Rectangle	$P = 2l + 2w$ or $P = 2(l + w)$
Circumference	Circle	$C = 2\pi r$ or $C = \pi d$
Area	Rectangle	$A = lw$ or $A = bh$
	Triangle	$A = \frac{1}{2}bh$ or $A = \frac{bh}{2}$
	Trapezoid	$A = \frac{1}{2}(b_1 + b_2)h$ or $A = \frac{(b_1+b_2)h}{2}$
	Regular polygon	$A = \frac{1}{2}aP$
	Circle	$A = \pi r^2$
P represents the perimeter of the base of a three-dimensional figure.		
B represents the area of the base of a three-dimensional figure.		
Surface Area	Cube (total)	$S = 6s^2$
	Prism (lateral)	$S = Ph$
	Prism (total)	$S = Ph + 2B$
	Pyramid (lateral)	$S = \frac{1}{2}Pl$
	Pyramid (total)	$S = \frac{1}{2}Pl + B$
	Cylinder (lateral)	$S = 2\pi rh$
	Cylinder (total)	$S = 2\pi rh + 2\pi^2$ or $S = 2\pi r(h + r)$
	Cone (lateral)	$S = \pi rl$
	Cone (total)	$S = \pi rl + \pi r^2$ or $S = \pi r(l + r)$
	Sphere	$S = 4\pi r^2$
Volume	Prism or Cylinder	$V = Bh$
	Pyramid or Cone	$V = \frac{1}{3}Bh$
	Sphere	$V = \frac{4}{3}\pi r^3$
Special Right Triangles	30°, 60°, 90°	$x, x\sqrt{3}, 2x$
	45°, 45°, 90°	$x, x, x\sqrt{2}$
Pythagorean Theorem		$a^2 + b^2 = c^2$
Distance Formula		$d = \sqrt{(x_2 - x_1)^2 + (y_2 - y_1)^2}$
Slope of a Line		$m = \frac{y_2 - y_1}{x_2 - x_1}$
Midpoint Formula		$M = \left(\frac{x_1 + x_2}{2}, \frac{y_1 + y_2}{2}\right)$
Quadratic Formula		$x = \frac{-b \pm \sqrt{b^2 - 4ac}}{2a}$
Slope-Intercept Form of an Equation		$y = mx + b$
Point-Slope Form of an Equation		$y - y_1 = m(x - x_1)$
Standard Form of an Equation		$Ax + By = C$
Simple Interest Formula		$I = prt$

Inches

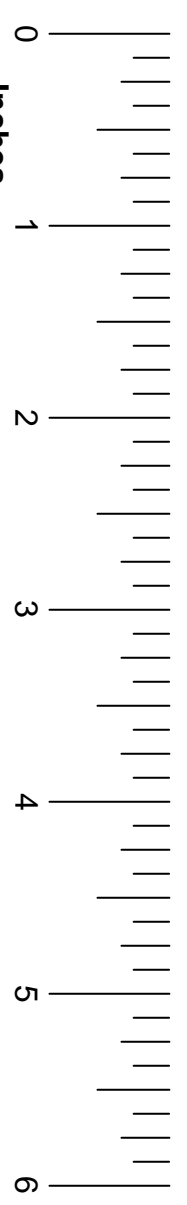

Taking a test can be very stressful, especially when you have a limited amount of time to complete the test. Stress can cause an individual to do poorly on a test. A student needs to be mentally prepared in order to be successful on a test. Below are 10 tips for success.

1. Have a Positive Attitude

A positive attitude goes a long way toward success. Believe you will do well. If you come across a question you cannot answer, believe that you can answer it later. Future questions may give clues as to how to solve it.

2. Make a Plan

Determine what your strengths and weaknesses are. Focus on studying what you do not know, and spend less time studying topics you find easy.

3. The Night Before

Cramming does not work. If you've followed a study plan, the night before the test you should do a quick review and get to bed early. Your brain and body need sleep to function well, so do not stay up late!

4. The Morning of the Test

Did you know that you think better when you have a full stomach? Eat a balanced breakfast the morning of the test. Get to school early and do a ten-minute power study right before the test, so your brain is turned on and tuned up.

5. Test Time

Before the test begins, make sure you have everything you will need – extra pencils, erasers, and your calculator. Understand how the test is scored: There are no penalties for a wrong answer. Even if you have no idea what the answer is, it is better to guess than to leave it blank. Read the instructions! You want to make sure you are marking answers correctly.

6. Manage Your Time

Scan through the test quickly before starting. Answering the easy questions first can be a time saver and a confidence builder. Plus, it saves more time for you to focus on the hard stuff.

7. I'm Stuck!

Those tricky problems can knock you off balance. Do not get worried or frustrated. Reread the question to make sure you understand it, and then try to solve it the best way you know how. If you are still stuck, circle it and move on. You can come back to it later. If you come back to it and are still unsure, just make an educated guess.

8. Multiple-Choice Questions

Process of elimination can help you choose the correct answer in a multiple-choice question. Start by crossing off the answers that cannot be right. Then, spend your time focusing on the possible correct choices before selecting your answer. Try to use logic to eliminate unreasonable answer choices.

9. Neatness Counts

Fill in the score sheet carefully. For machine-scored tests, erase marks may affect your score sheet. Make sure you are confident in your answer when you enter it on the score sheet. If you are unsure of a question, leave it blank and fill it in at the end.

10. I'm Done!

Not so fast – when you complete the last item on the test, remember that you're not done yet. First, check the clock and go back to review your answers, making sure that you didn't make any careless mistakes. Make sure that your answers on the bubble sheet match the right question number, and make sure you did not leave any questions blank. Spend the last remaining minutes going over the hardest problems before you turn in your test.

A difficult aspect of taking a standardized test is finishing on time. With timed tests, an individual can feel overwhelmed by the number of questions they have to answer. The key is not to get stressed about trying to finish on time. If you do not answer all the questions, it does not mean you will fail.

In addition, these mental math tips may help you answer questions faster.

Multiplying numbers that end with zeros:

Find the product of 70×300

$$\begin{array}{c} \textcircled{70} \times \textcircled{300} \\ \swarrow \quad \searrow \\ 21 \end{array} \quad \text{Multiply the numbers in front of all the zeros.}$$

We cannot forget about all the zeros in the problem. There were three all together.

$$\begin{array}{c} \textcircled{70} \times \textcircled{300} \\ \swarrow \quad \searrow \\ 21,000 \end{array} \quad \text{Add the zeros to the product of the first digits.}$$

The answer is 21,000.

Let's try one more. Find the product of 100×250

$$\begin{array}{c} \textcircled{100} \times \textcircled{250} \\ \swarrow \quad \searrow \\ 25,000 \end{array}$$

The answer is 25,000.

Mental math may be faster than using a calculator.

Dividing numbers that end with zeros:

Find the quotient of $5,400,000 \div 90,000$

$$5,400,000 \div 90,000$$

Cross out the same number of zeros in both numbers (the second number has fewer zeros).

$$540 \div 9$$

Now perform the division.

9 goes into 54 exactly 6 times.

The zero is then brought down. So, 9 goes into 540 exactly 60 times.

Let's try one more. Find the quotient of $240,000 \div 30$

$$240,000 \div 30$$

$$24,000 \div 3$$

The quotient is 8,000.

Calculating percentages:

What is 10% of 295?

To calculate the percent of a number we multiply the number by the decimal form of the number.

$$10\% \text{ of } 295 = .1(295) = 29.5$$

When we multiply a number by .1, the product is that number with the decimal point moved one place value to the left. So, to take 10% of any number, move the decimal point one place value to the left.

What is 10% of 57?

$$10\% \text{ of } 57 = 5.7$$

Percents that are multiples of 10 are also easy to calculate.

$$20\% = 2 \times 10\%$$

$$30\% = 3 \times 10\%$$

$$40\% = 4 \times 10\%$$

and so on.

What is 20% of 75?

$$2 \times 10\% \text{ of } 75 = 2 \times 7.5 = 15$$

20% of 75 is 15.

Let's apply this to a problem.

Example

Marta is buying a pair of shoes that are marked 30% off. If the original price of the shoes is \$80, what is the sale price?

A \$8

B \$72

C \$24

D \$56

Solution

First, we will calculate what 30% of \$80 is.

$$3 \times 10\% \text{ of } \$80 = 3 \times \$8 = \$24$$

Next, we will subtract this from the original price

$$\$80 - \$24 = \$56$$

The sale price is \$56, so choice **D** is the answer.

The numbers will not always be this easy to work with, but we can use rounding to estimate our answer.

Example

Erin goes to the store and buys \$84.95 worth of merchandise. If the sales tax is 8.75% what will her total be?

- A** \$7.43 **B** \$92.38
C \$142.74 **D** \$95.45

Solution

First, we know that the total bill has to be more than the initial total, so we can eliminate choice **A** as an answer. It may be difficult to find 8.75% of \$84.95, but if we round, we can estimate our answer. Let's find 10% of \$85.

$$10\% \text{ of } \$85 = \$8.50$$

To find the total, add the sales tax to the initial price, \$85.

$$\$85 + \$8.50 = \$93.50$$

We know this estimate should be above the actual value since we rounded up. The closest answer to this estimate is choice **B**.

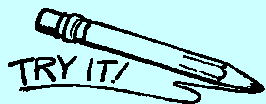

Answer the following questions without using a calculator.

1) Find the length of segment AE .

- A** 1200 ft.
B 1500 ft.
C 1800 ft.
D 2000 ft.

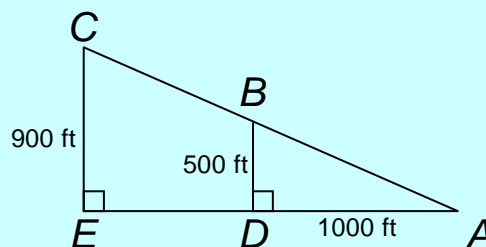

2) Find the area of the sector shown (*Hint*: Estimate for the value of π)

- A 9.42 cm²
- B 8.12 cm²
- C 3.14 cm²
- D 6.28 cm²

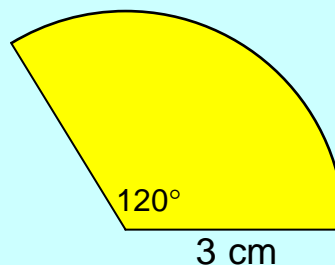

Problem Solving Tip

Mental math may be helpful for computing arithmetic quickly, but if you are not very confident in your mental math skills, you can use a calculator.

Since the TAKS exam is multiple-choice, if you can eliminate illogical answer choices, it greatly increases your chances of guessing correctly. Reasoning can be a great tool for eliminating impossible answer choices.

Example

$\triangle ABC$ is isosceles. \overline{AC} is 14 cm long. Find the length of \overline{BD} .

- A 7 cm
- B 14 cm
- C 24 cm
- D 25 cm

Solution

Let's use reasoning to eliminate the answers that do not make sense. First, \overline{BD} is the altitude of $\triangle ABC$. This means that $\triangle ABD$ is a right triangle. Since

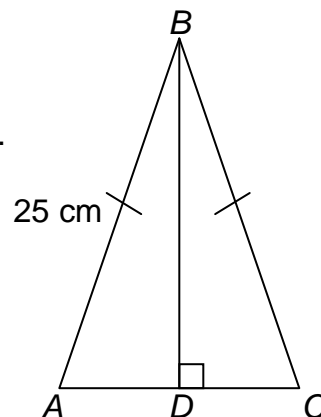

\overline{AB} is the hypotenuse of this triangle, it must be the longest side. This means that \overline{BD} cannot be 25 cm.

~~D 25 cm~~ Cross out choice **D**.

We know that $AD = \frac{1}{2}AC$ because the altitude drawn from the vertex of an isosceles triangle bisects the base. This means that $AD = 7$ cm. The triangle inequality tells us that $AD + BD > AB$ (since \overline{AB} is the longest side).

$$AD + BD > AB$$

$$7 + BD > 25$$

If we substitute 7 cm and 14 cm for \overline{BD} , the inequality is not true.

~~A 7 cm~~ Cross out choice **A**

~~B 14 cm~~ and choice **B**.

By process of elimination, choice **C** must be the answer.

To prove this is true, we will use the fact that $\triangle ABD$ is a right triangle. We know that 7, 24, 25 is a Pythagorean triple. One of the legs is 7, and the hypotenuse is 25. This means that the other leg, \overline{BD} , must be 24. We could also use the Pythagorean Theorem to find the missing length.

$$(AD)^2 + (BD)^2 = (AB)^2$$

$$7^2 + (BD)^2 = 25^2$$

$$49 + (BD)^2 = 625$$

$$(BD)^2 = 576$$

$$BD = 24$$

Problem Solving Tip

On the TAKS exam, pictures are usually drawn to scale. If you are unsure of a geometry question, you can guess by comparing the unknown length to given lengths.

Example

Which equation best represents the area of the shaded rectangle located diagonally in the cube?

A $A = x^3\sqrt{2}$

B $A = x^2\sqrt{2}$

C $A = \frac{x^3}{2}$

D $A = x^2\sqrt{3}$

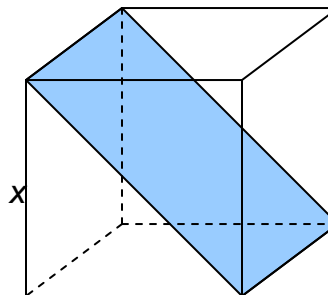
**Solution**

Since the side given to us, x , has an exponent of 1, we know that the area using this should be in square units (area squares the unit given). Thus, we can eliminate choices **A** and **C**, because they are cubed. If we were to guess now, we have a 50% chance of getting the question right. In a cube, all sides are the same length, so the diagonal forms a 45, 45, 90 right triangle. This means the length of the diagonal is $x\sqrt{2}$. Thus, the area is $x(x\sqrt{2}) = x^2\sqrt{2}$, which is choice **B**.

Example

Wanda's car gets 20 miles per gallon of gas. If she takes a 360-mile road trip, how many gallons of gas will Wanda's car use?

A 18 gallons

B 180 gallons

C 1.1 gallons

D 11 gallons

Solution

If Wanda's car gets 20 miles per gallon, that means that she can go 20 miles with one gallon of gas, 40 miles with two gallons, 60 miles with three gallons, and so on. Immediately, we know choice **C** cannot be the answer. We can also assume that choice **B** is far too many gallons of gas for the trip. Again, we have a 50% chance of guessing correctly. If we multiply the number of gallons

by the miles per gallon, we know how far she can go. Since $18 \times 20 = 360$, we know that 18 gallons will give us the amount of gas we need to complete the road trip. So, choice **A** is the answer.



Use reasoning to eliminate illogical answer choices.

- 3) In the figure provided, $AD = 20$ cm. $\overline{AB} \parallel \overline{XS} \parallel \overline{CD}$, and $\overline{AC} \perp \overline{AB}$.

Which is closest to the length of \overline{AC} ?

- A 12 cm
- B 14 cm
- C 28 cm
- D 34 cm

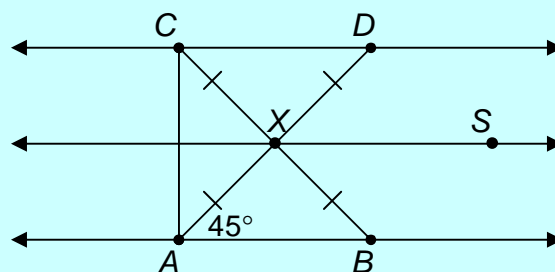

- 4) As a waiter in a restaurant, Miguel works 8-hour shifts. He earns \$5 per hour and keeps 80% of his tip money. How much tip money does he need to receive per shift to earn a total of exactly \$80 before taxes are deducted?
- A \$30
 - B \$40
 - C \$50
 - D \$70
- 5) Mr. Rosa has a square garden that has a perimeter of 36 feet. What is the approximate length of the diagonal of his square garden?
- A 9 feet
 - B 13 feet
 - C 16 feet
 - D 18 feet

 **Review**

Know these concepts:

1. To prepare for the test, get a good night's sleep and eat a good breakfast.
2. During the test, have confidence in yourself and do not worry if you have to guess on some questions.
3. Use reasoning to eliminate unrealistic answer choices.
4. Use mental math to answer questions quicker.
 - a. To multiply numbers with lots of zeros, multiply the numbers in front of the zeros, then add all the zeros at the end of the product.
 - b. To divide numbers with lots of zeros, cancel out all the zeros that are common among the dividend and divisor. Then, divide.
 - c. To find percents that are multiples of 10, move the decimal point one place to the left, then multiply by the number in the tens place.

**Practice Problems**
Lesson 29

Directions: Write your answers in your math journal. Label this exercise

TAKS Review – Lesson 29.

- 1) Tony goes to the store and sees a box of his favorite cookies. On the pack it says 20% more free. If the box has 30 cookies, how many cookies were free?
A 25 cookies **B** 5 cookies
C 30 cookies **D** 10 cookies

- 2) Darla makes clay pots. Her overhead costs are \$600 per week, and she pays an additional \$5 per pot in material. If Darla sells her pots for \$20 each, how many does she need to sell each week before she can make a profit?
A 20 **B** 30
C 40 **D** 50

TAKS Review

- 3) John is flying his plane at an altitude of 3000 feet. He sees a farm at an angle of depression of 30° . What is John's approximate horizontal distance from the farm?

- A 1500 feet
- B 5196 feet
- C 6000 feet
- D 6139 feet

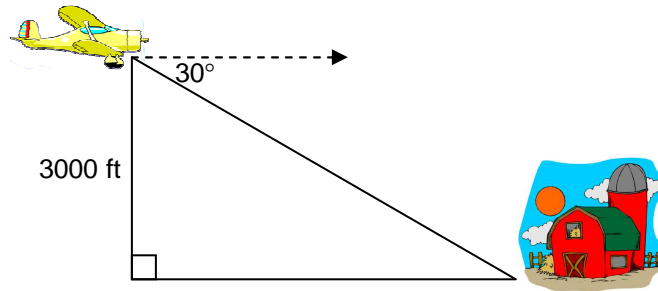

- 4) A metal rod, 2 ft. long weighs 5 lbs. If the ratio of length to weight is proportional, how heavy is a 5 ft. metal rod?
- A 2 pounds
 - B 7.5 pounds
 - C 10 pounds
 - D 12.5 pounds



- 1) C
- 2) A
- 3) B (You could eliminate choices **C** and **D** right away, because \overline{AC} could not be bigger than \overline{AD} . $\triangle AXC$ is a 45-45-90 triangle, and the legs are 10 cm. Thus, the hypotenuse, \overline{AC} , is $10\sqrt{2} \approx 14$ cm.)
- 4) C (He makes \$40 without tips during an 8-hour shift. Thus, choice **A** would not be enough in tips to make \$80. Since he does not keep 100% of his tips choice **B** is also not enough. Solve the following equation for x to find the amount of tip money Miguel needs to earn. $40 + .8x = 80$)

5) B

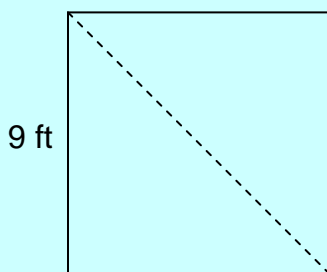

(The sides of the square garden are 9 feet each. Thus, the diagonal could not be 9 feet eliminating choice **A**. Also, the diagonal cannot be 18, because the triangle formed by the sides and the diagonal would not exist because of the triangle inequality. So, choice **D** does not work either. The triangle formed is a 45-45-90 triangle. The legs are 9 feet and the hypotenuse is $9\sqrt{2} \approx 13$ feet.)

TAKS Review

NOTES

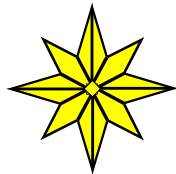

End of Lesson 29